





Primelite Manufacturing Corp

407 S Main St, Freeport, NY 11520

Phone: 516-868-4411 | Fax: 516-868-4609
 sales@primelite-mfg.com | www.primelite-mfg.com

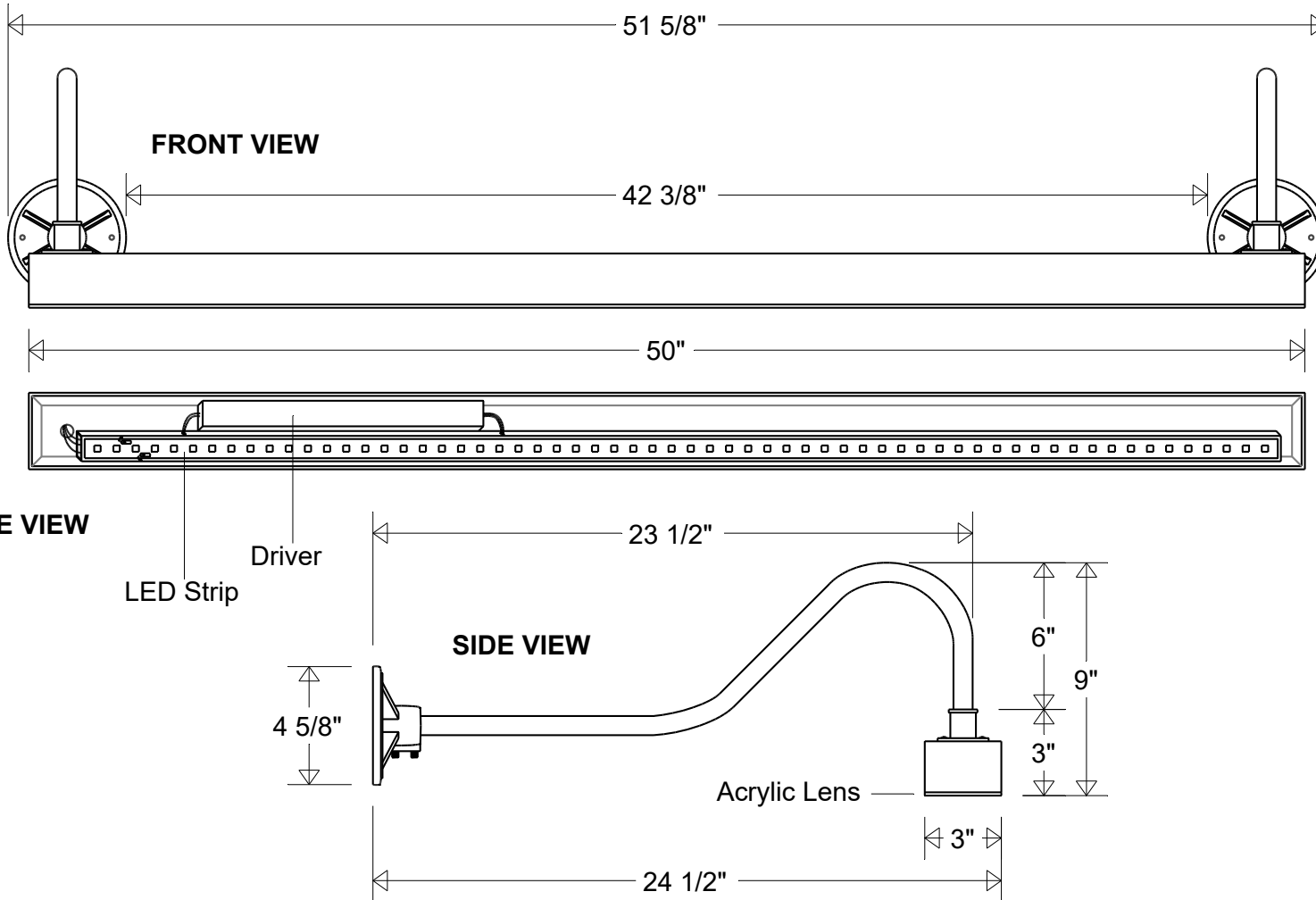
PART # #5750/850 LED 50	LAMP Built-In LED	VOLTAGE 120-277 V	COLOR Powder Coated Paint
JOB NAME			TYPE Linear Sign Light



Lamp: LED 50 Strip 35K or 50K: 7,795 Lumens 	Name	Date	Sign Light #5750/850 LED 50			
	Drawn	CB				07/2021
	Checked			51 5/8" L 24 1/2" Ext 9" H 47" Center to Center Arms Acrylic Lens : White (-3) Clear (-4) Frosted (-5)		
	ENG Appr.					
MFR Appr.			Size	Drawing No.	Rev	
Construction: Aluminum Acrylic	QA		A	0001	A	
Unless Otherwise Specified: Dimensions in Inches	Weight		Scale	CAD File	Sheet 1 of 1	

Revisions				
Zone	Rev	Description	Date	Approved