



Primelite Manufacturing Corp.

407 S Main St, Freeport, NY 11520
 Phone: (516) 868-4411 | Fax: (516) 868-4609
 sales@primelite-mfg.com | www.primelite-mfg.com

PROUDLY MADE IN THE USA SINCE 1962!
"SPECIALTIES ARE OUR SPECIALTY!"

Job Info

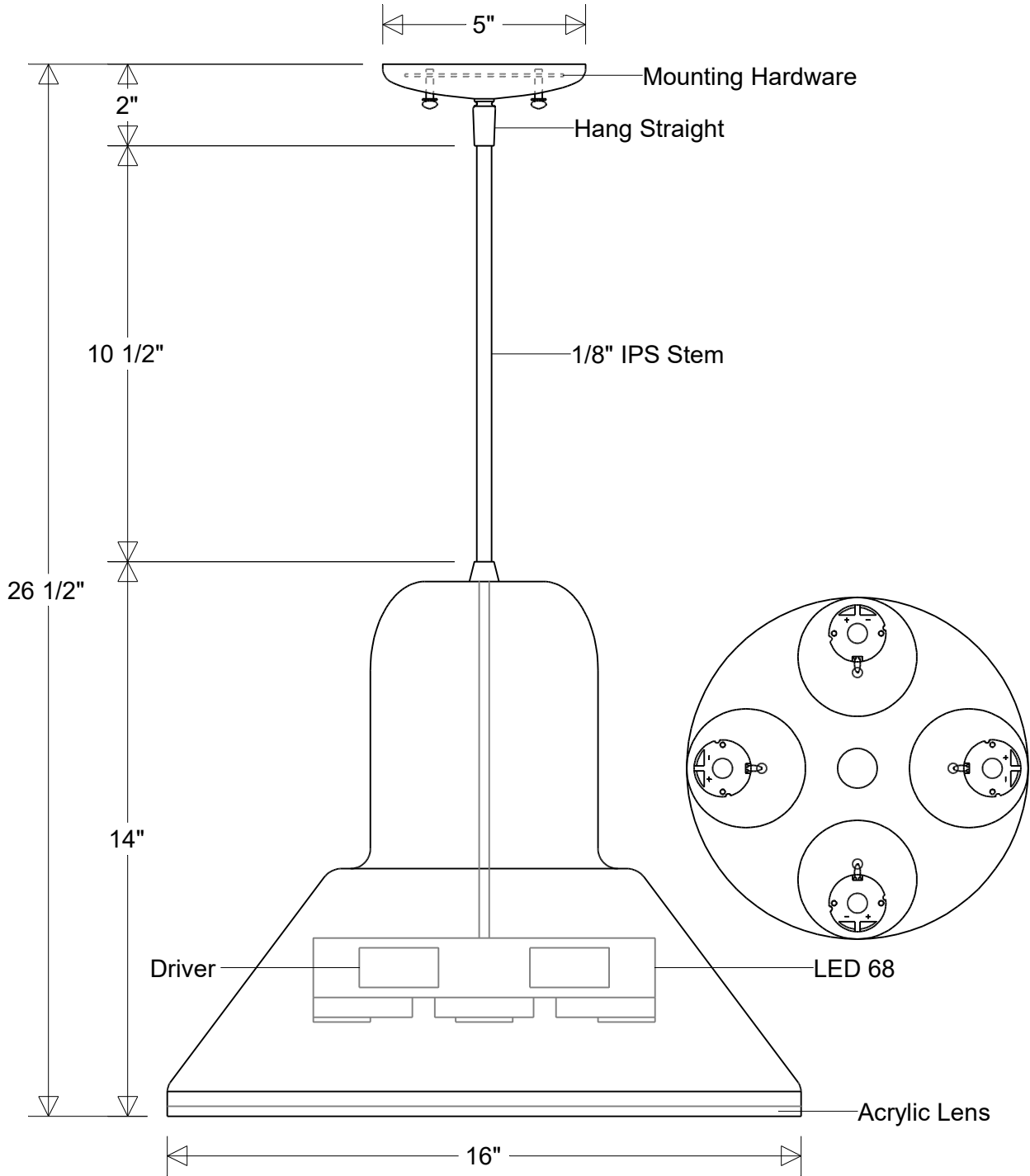

#37/16-S-12 LED 68

16" Dia | 26 1/2" H
 12" x 1/8" IPS Stem

Lamp: 68 W LED
 12,000 Lumens
 3K | 4K | Others available

Voltage:
 120-277 V

Finish:
 29 Oven Baked
 Powder Coated Paints

Material:
 Aluminum | Steel
 Clear Acrylic Lens

Drawn:
 CB
 07/2025

Note:
 All dimensions are nominal.
 Actual dimensions may vary.

Scale:
 1/4

Approvals