



# Primelite Manufacturing Corp.

407 S Main St, Freeport, NY 11520  
 Phone: (516) 868-4411 | Fax: (516) 868-4609  
 sales@primelite-mfg.com | www.primelite-mfg.com

**PROUDLY MADE IN THE USA SINCE 1962!**  
**"SPECIALTIES ARE OUR SPECIALTY!"**

Job Info

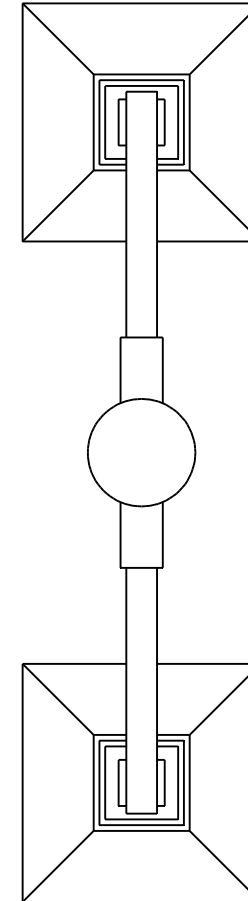
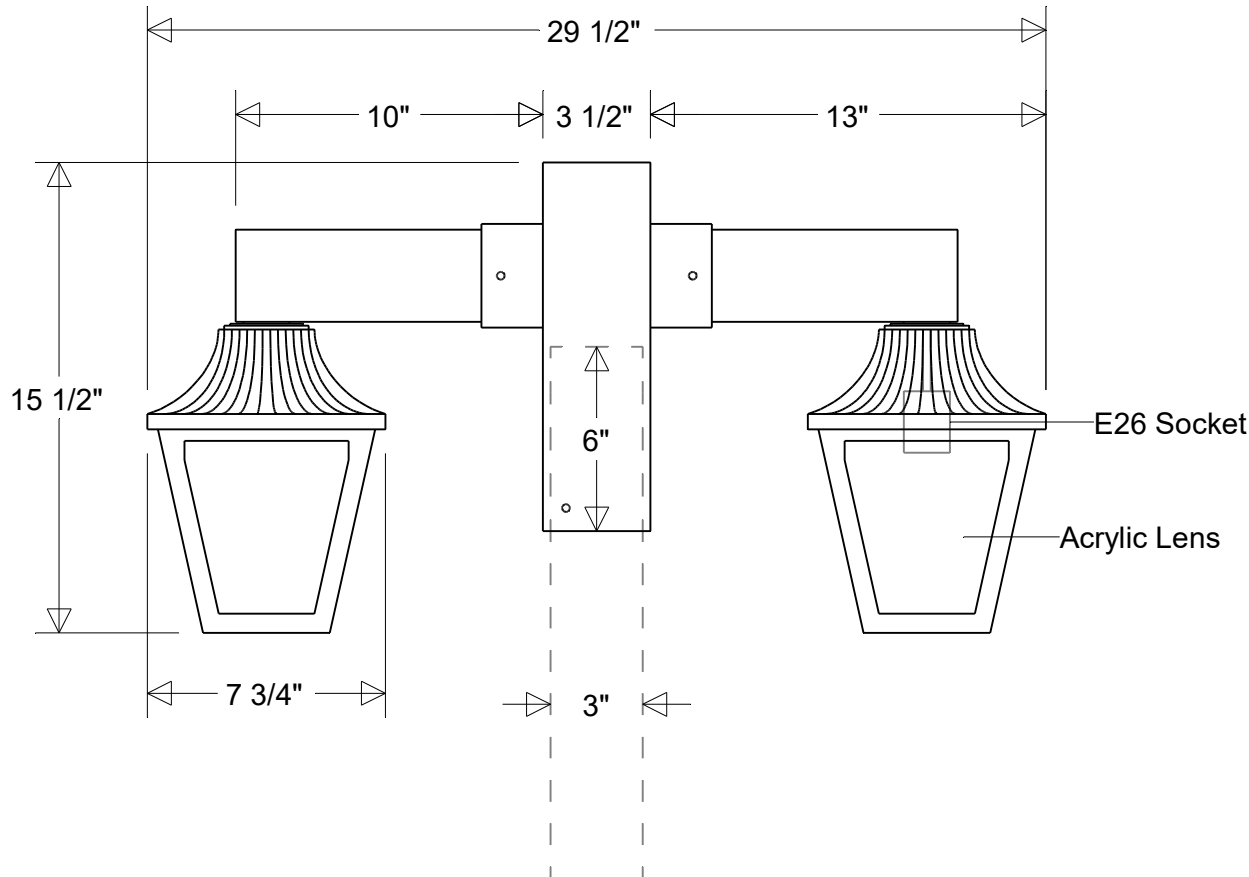

## #1332/\* T2

7 3/4" W | 29 1/2" Ext | 15 1/2" H | 3" Post Fitter  
 Lens: Smoke (\*1) | White (\*3) | Clear (\*4) | Frost (\*5)

<b>Lamp: E26 Socket</b> Max Wattage: 150 W each Number of Sockets: 2 120 V	<b>Finish:</b> 29 Oven Baked Powder Coated Paints	<b>Drawn:</b> CB 04/2026	<b>Scale:</b> 1 / 6.25	<b>Approvals</b>	
	<b>Material:</b> Aluminum Acrylic Lens	<b>Note:</b> All dimensions are nominal. Actual dimensions may vary.			