

Revisions				
Zone	Rev	Description	Date	Approved

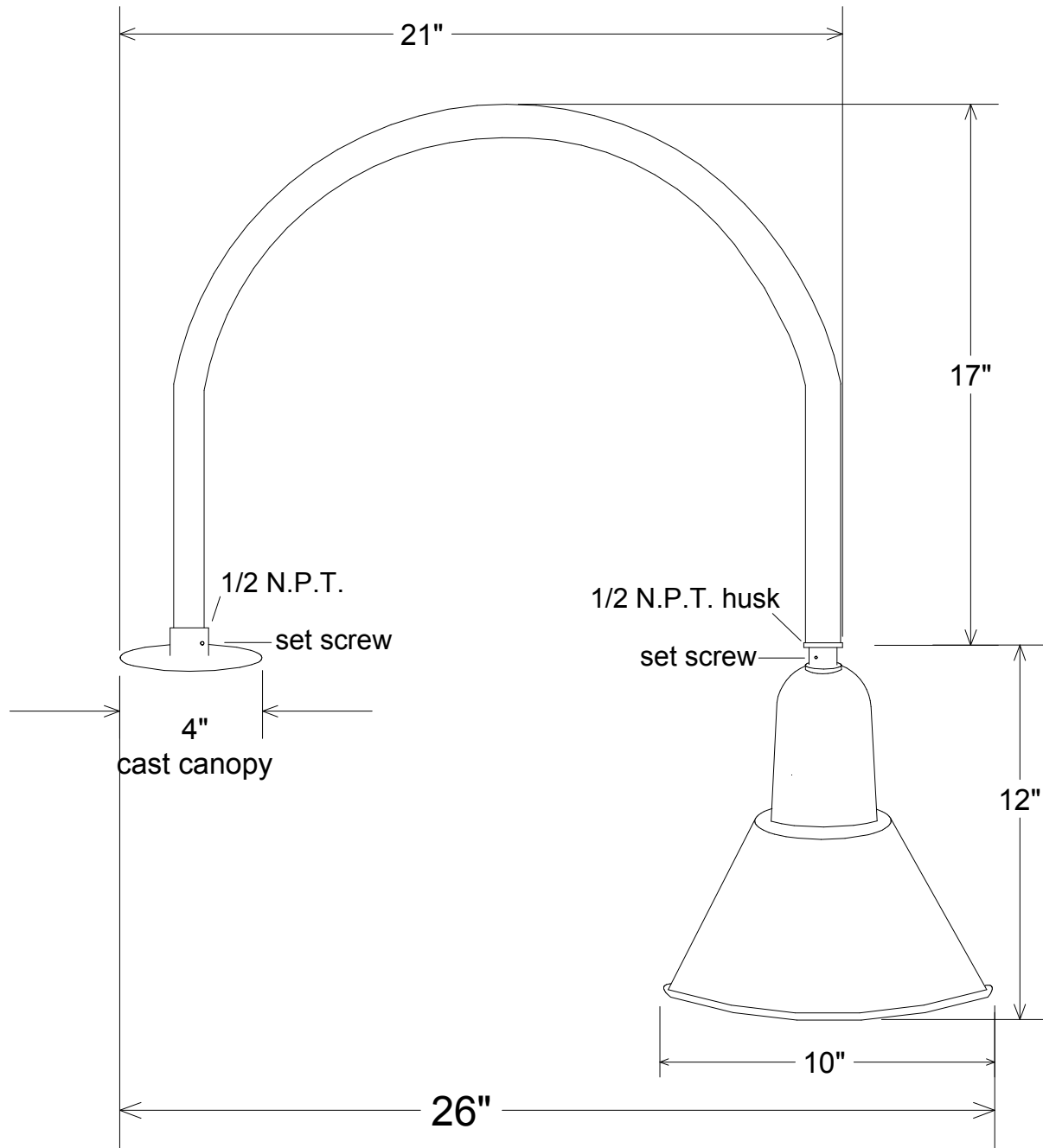

<b>Unless Otherwise Specified:</b> Dimensions in Inches Tolerances: Fractional ± Angular: Mach ± Bend ± Two Place Decimal ± Three Place Decimal ±	<b>Drawn</b>	<b>Name</b>	<b>Date</b>	<b>Primelite Mfg. Corp.</b>  <b>37-10/852</b>  <b>10" Balast Shade Palpit Mount</b>		
	T.A.R.	10/22/09				
	<b>Checked</b>					
	<b>ENG Appr.</b>					
	<b>MFR Appr.</b>					
	<b>QA</b>					
<b>Comments</b>	CAD Generated Drawing Do Not Manually Update			<b>Size</b>	<b>Drawing No.</b>	<b>Rev</b>
<b>Construction: All Aluminum</b>				<b>A</b>	<b>0001</b>	<b>A</b>
<b>Pipe Size: 1/2"</b>				<b>Scale</b>	<b>1:7</b>	<b>CAD File</b>
<b>Lamp: 1-150A</b>				<b>Sheet</b>	<b>1 of 1</b>	