

Revisions			Date	Approved
Zone	Rev	Description		

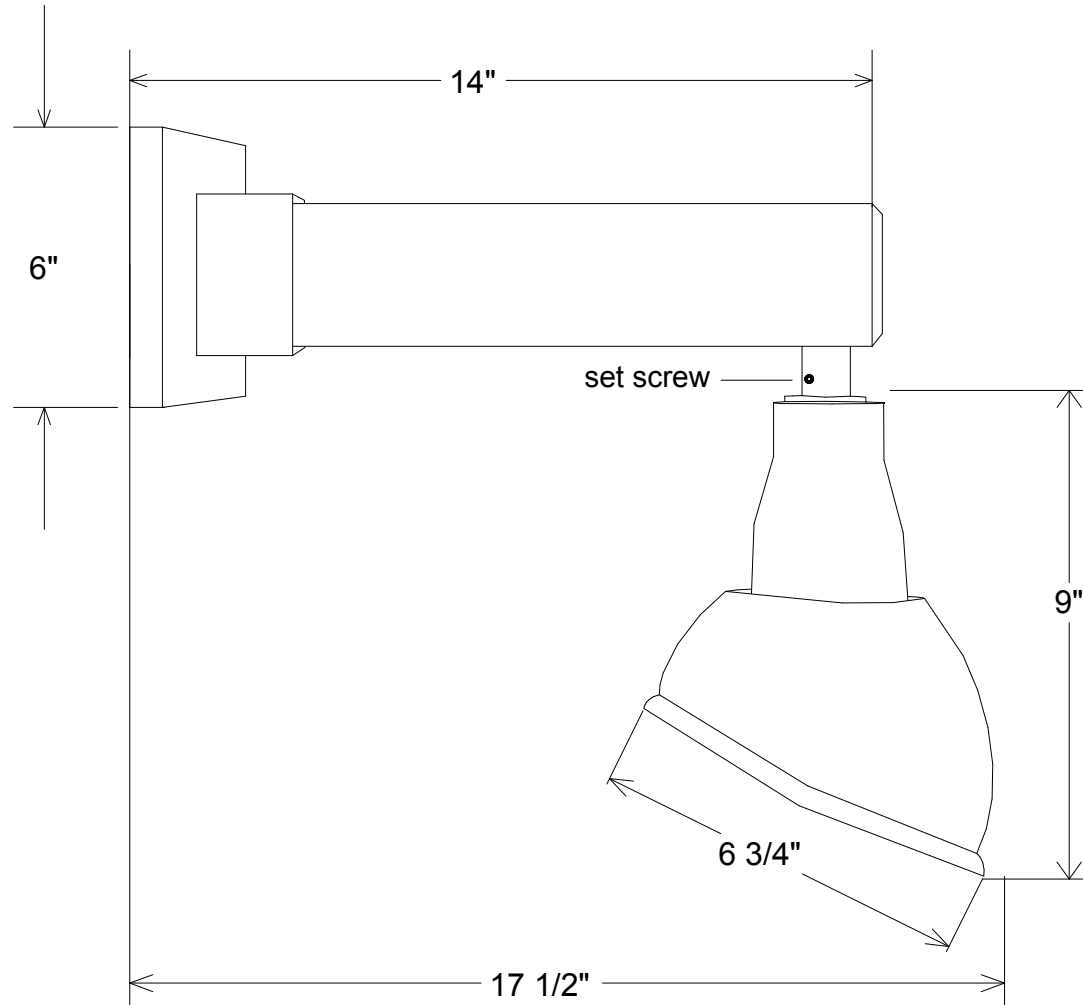

Unless Otherwise Specified: Dimensions in Inches Tolerances: Fractional ± Angular: Mach ± Bend ± Two Place Decimal ± Three Place Decimal ±	Name	Date	Primelite Mfg. Corp. 15/861		
	Drawn	T.A.R.			05/21/10
	Checked				
	ENG Appr.				
	MFR Appr.				
QA			Size Drawing No. Rev A 0001 A		
Comments	CAD Generated Drawing Do Not Manually Update				
Construction: All Aluminum					
Pipe Size: 1/2"					
Lamp: 1-100A			Scale 1:4 CAD File	Sheet 1 of 1	